

QPS2-9K-20000-A-1

SPDT, 9kHz~20GHz, Absorptive

Features:

- * Low Insertion Loss
- * High Isolation

Applications:

- * Wireless
- * Transmitter
- * Laboratory Test
- * Radar

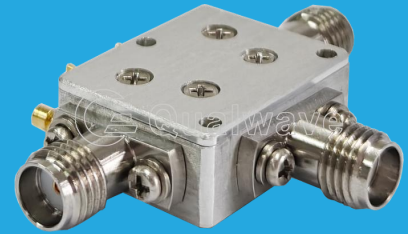

Electrical

Frequency:	9kHz~20GHz
Insertion Loss:	3dB max.
Isolation:	30dB min.
VSWR (On state):	2 typ.
Input Power (P1dB):	24dBm typ. @1~20GHz
Switching Time:	25ns typ.
Voltage:	+5V DC typ.
Current:	10mA typ.
Control:	High - 1 @2.5~5V Low/NC - 0 @0~0.8V

Absolute Maximum Ratings*1

RF Input Power:	27dBm
Control Voltage:	+5.5V

[1] Permanent damage may occur if any of these limits are exceeded.

Mechanical

Size*2:	20*16*8mm 0.787*0.63*0.315in
RF Connectors:	SMA female (Removable)
Power Supply Connectors:	Feed through/Terminal post
Mounting:	3-Φ1.8mm through-hole

[2] Exclude connectors.

Environmental

Operating Temperature:	-45~+85°C
Non-operating Temperature:	-55~+125°C

Outline Drawings

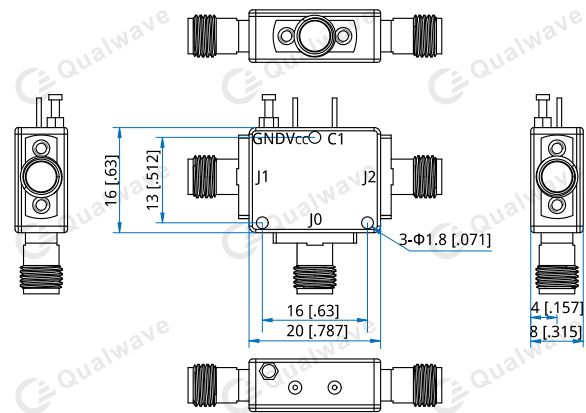

Unit: mm [in]

Tolerance: ±0.2mm [±0.008in]

Control True Table

C1	Connection
0	J0 - J1 On
1	J0 - J2 On

How To Order

QPS2-9K-20000-A-1

Customization is available upon request.

Typical Performance Curves

Input VSWR (J0) vs. Frequency

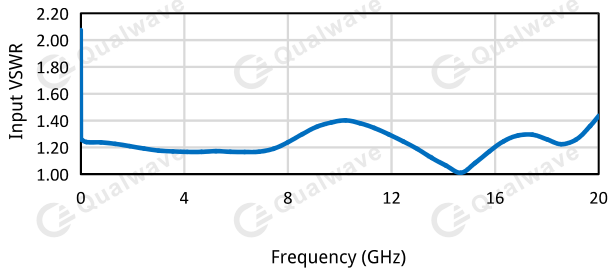

Output VSWR (Off state) vs. Frequency

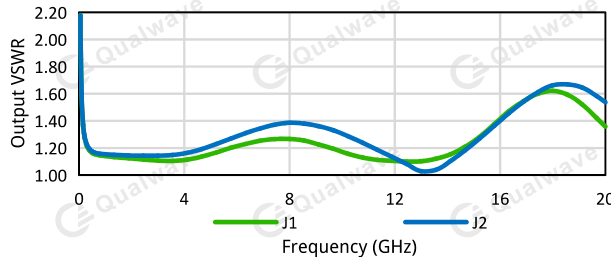

Output VSWR (On state) vs. Frequency

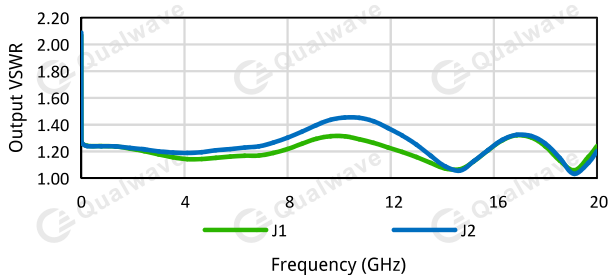

Insertion Loss vs. Frequency

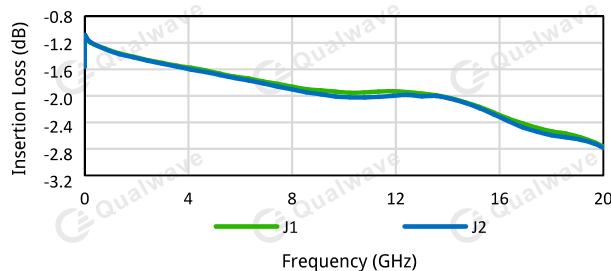

Isolation vs. Frequency

