

QLA-1000-6000-25-10

1~6GHz, 25dB, 1.0dB

Features:
 * Broadband
 * Low Noise

Applications:
 * Wireless
 * Receiver
 * Laboratory Test
 * Radar



Description

This product series features ultra-wideband low-noise amplifiers (LNAs) operating from 1 to 6GHz. The lineup includes:

- LNA modules powered by 5-15V DC, where increasing supply voltage enhances gain and output power;
- LNA systems with integrated switching-mode power supplies (SMPS) accepting 85-265V AC input, recommended for most applications;
- LNA systems employing linear-regulated power supplies for 220V AC operation, delivering optimal performance where extreme power purity is critical.

Electrical

Frequency:	1~6GHz
Gain:	25dB typ.
Gain Flatness:	±0.3dB typ.
Output Power (P1dB):	13dBm typ.
Noise Figure:	1.0dB typ.
Spurious:	-60dBc max.
VSWR:	1.8 typ.
Reverse Isolation:	-30dB min.
Voltage:	+5V DC (Outline A) +6~15V DC (Outline B) +85~+265V AC (Outline C) +220V AC (Outline D)
Current:	50mA typ. (Outline A, B)
Impedance:	50Ω

Absolute Maximum Ratings*1

RF Input Power:	+18dBm
Voltage:	+6V (Outline A) +20V (Outline B)

[1] Permanent damage may occur if any of these limits are exceeded.

Mechanical

RF Connectors: SMA Female (Removable)

Environmental

Operating Temperature:	-45~+85°C
Non-operating Temperature:	-55~+125°C

Outline Drawings

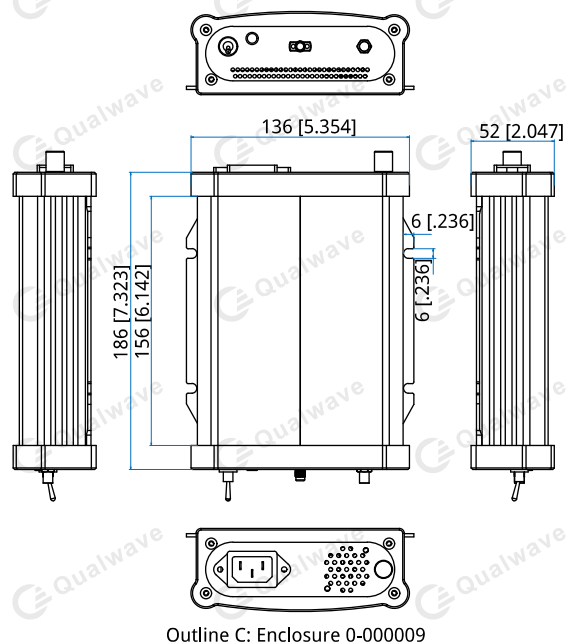
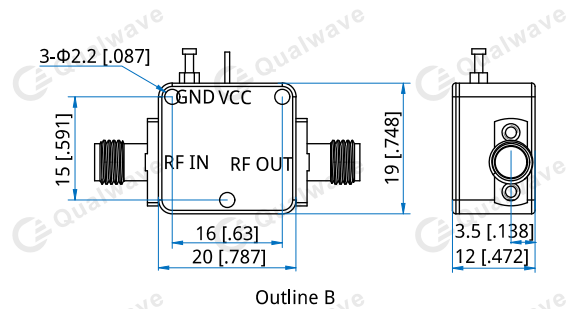
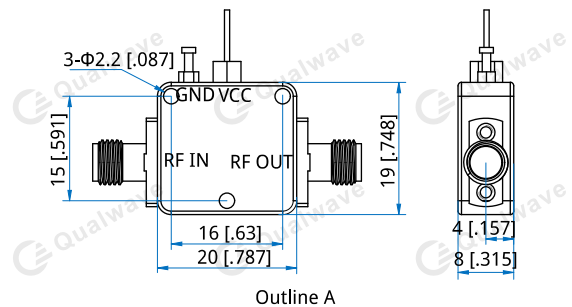

How To Order

QLA-1000-6000-25-10 - Outline A

QLA-1000-6000-25-10-1 - Outline B

QLAS-1000-6000-25-10 - Outline C, AC-powered unit integrates a switching-mode power supply.

QLAS-1000-6000-25-10-1 - Outline D, AC-powered unit integrates a linear-regulated power supply.

Customization is available upon request.

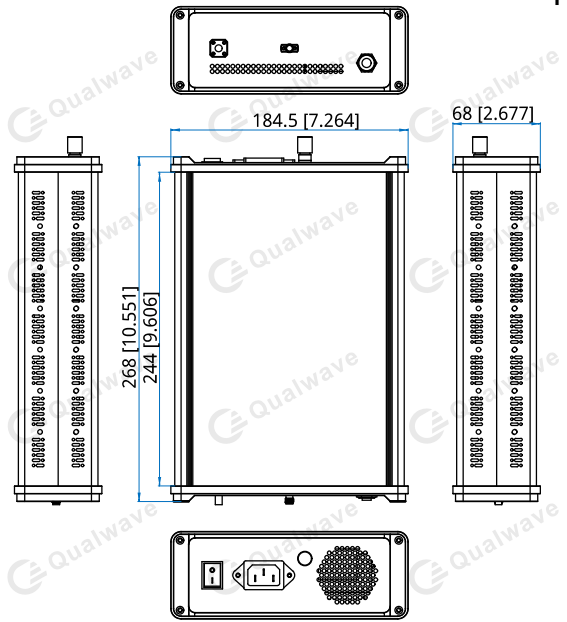

Outline D: Enclosure 0-000006

Unit: mm [in]

Tolerance: $\pm 0.5\text{mm}$ [$\pm 0.02\text{in}$]

Typical Performance Curves

