

QRHA1150

0.64~0.96GHz, WR-1150

Features:
* Broadband

Applications:
* Wireless
* Transceiver
* Laboratory Test
* Broadcast

Electrical

Frequency: 0.64~0.96GHz
Gain: 10dB
VSWR: 1.4 max.

Mechanical

Interface: WR-1150 (BJ8)
Material: Aluminium

Outline Drawings

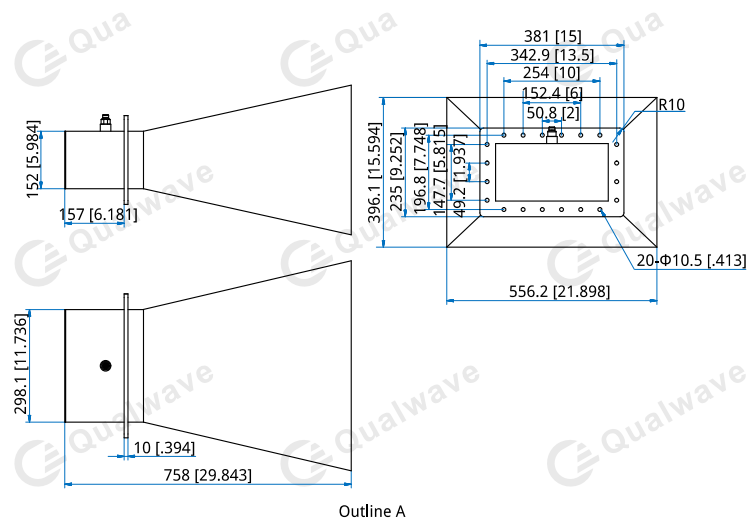

Unit: mm [in]

Tolerance: $\pm 0.5\text{mm}$ [$\pm 0.02\text{in}$]

How To Order

QRHA1150-X-Y-Z

X: Gain in dB

10dB - Outline A

Y: Connector type if applicable

Z: Installation method if applicable

Connector naming rules:

N - N Female (Outline A)

Examples:

To order an antenna, 0.64-0.96GHz, 10dB, WR-1150, N Female, specify QRHA1150-10-N.

Customization is available upon request.