

# QPS1-9000-10000-A

## SPST, 9~10GHz, Absorptive

**Features:**

- \* Low Insertion Loss
- \* High Isolation

**Applications:**

- \* Wireless
- \* Transmitter
- \* Laboratory Test
- \* Radar

**Electrical**

Frequency:	9~10GHz
Insertion Loss:	2.5dB max.
Isolation:	80dB min.
VSWR:	2 max.
Input Power (P1dB):	+23dBm typ.
Input Power Handling:	+30dBm typ.
Voltage:	+5/-5V DC typ.
Current:	+80/-60mA typ.
Control Voltage:	0/+3.3 (+5)V DC
Impedance:	50Ω

**Mechanical**

Size*1:	25.4*15.75*5.59mm 1*0.62*0.22in
Switching Time:	30nS typ.
RF Connectors:	SMA Female
Power Supply Connectors:	Feed Through/Terminal Post
Mounting:	4-Φ1.98mm through-hole

[1] Exclude connectors.

**Control True Table**

VC	Connection
H	On
L	Off

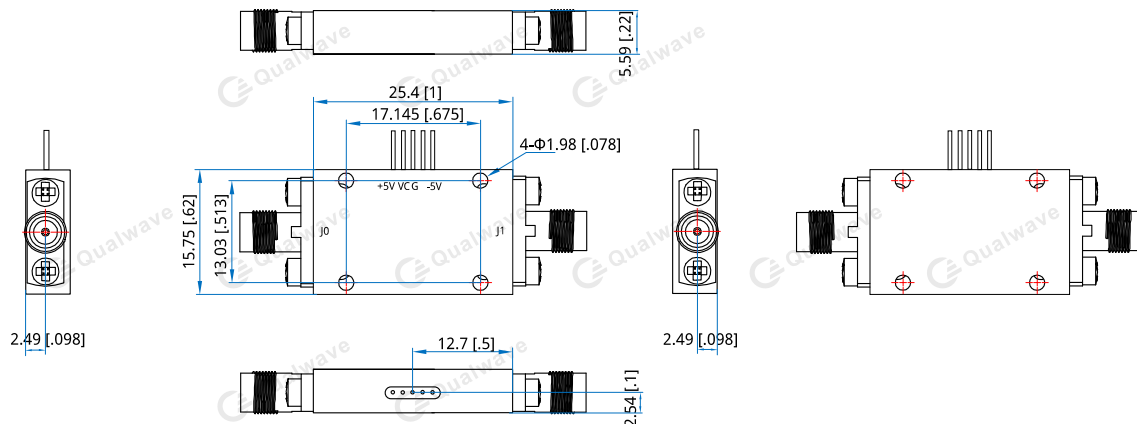
**Outline Drawings**

Unit: mm [in]

Tolerance: ±0.2mm [±0.008in]

**How To Order**

[QPS1-9000-10000-A](#)

Customization is available upon request.