

# QMPS180

## 180°/GHz

- Features:
- \* Low Insertion Loss
  - \* High Power
  - \* High Reliable

- Applications:
- \* Laboratory Test
  - \* Transmitter
  - \* Instrumentation
  - \* Wireless

### Electrical

Frequency: DC~4GHz  
 Impedance: 50Ω  
 Average Power: 100W  
 Peak Power<sup>\*1</sup>: 5KW

[1] Pulse width: 5us, duty cycle: 2%.

Frequency (GHz)	VSWR (max.)	Insertion Loss (dB, max.)	Phase Adjustment <sup>*2</sup> (°)
DC~1	1.4	1.0	0~180
DC~2	1.5	1.5	0~360
DC~3	1.5	1.75	0~540
DC~4	1.5	2.0	0~720

[2] Phase shift varies linearly corresponding to the frequency. For example, if the maximum phase shift is 360°@2GHz, the maximum phase shift is 180°@1GHz.

### Mechanical

Size<sup>\*3</sup>: 372\*76\*30.5mm  
 14.646\*2.992\*1.201in  
 Size<sup>\*4</sup>: 377\*76\*50.5mm  
 14.843\*2.992\*1.988in

Weight: 795g

RF Connectors: N Female, SMA Female  
 Outer Conductor: Nickle Plated Brass  
 Inner Conductor: Gold Plated Beryllium Bronze  
 Housing Material: Aluminum

[3] Analog.

[4] Digital.

### Environmental

Operating Temperature: -10~+50°C  
 Non-operating Temperature: -40~+70°C

### Outline Drawings

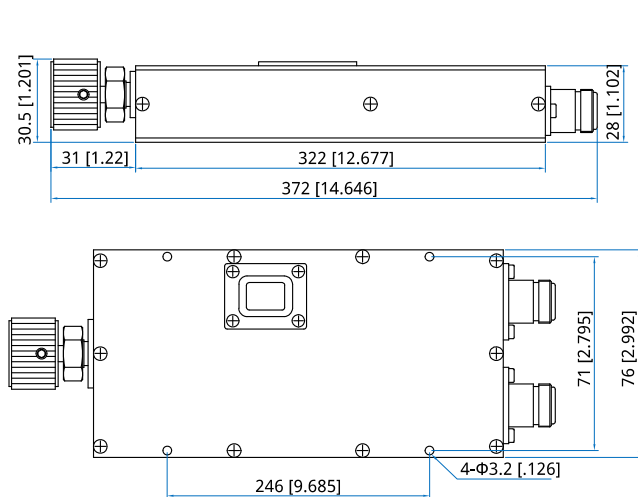

Outline A

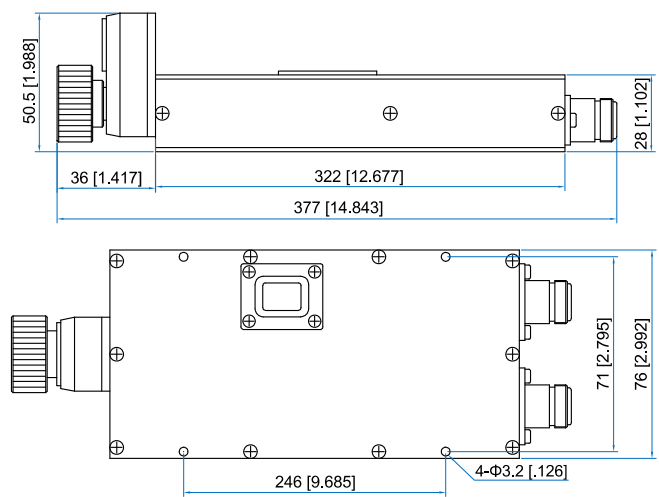

Outline B

Unit: mm [in]

Tolerance: ±0.2mm [±0.008in]

## How To Order

### QMPS180-X-Y-Z

X: Frequency in GHz

Y: Connector type

Z: Display

#### Examples:

To order a digital phase shifter, DC~3GHz, N female to N female, specify QMPS180-3-N-D.

Connector naming rules:

S - SMA

N - N

Display naming rules:

A - Analog (Outline A)

D - Digital (Outline B)

Customization is available upon request.