

QLA-5-1000-46-15

5~1000MHz, 46dB, 1.5dB

Features:
 * Small Size
 * Low Power Consumption

Applications:
 * Wireless
 * Transmitter
 * Laboratory Test

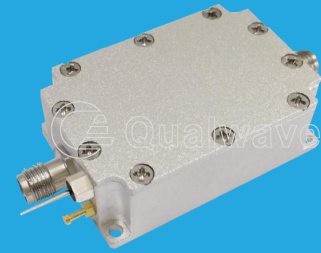

Electrical

Frequency:	5~1000MHz
Gain:	46dB typ.
Noise Figure:	1.5dB typ.
Output Power (P1dB):	20dBm typ.
Input VSWR:	2 typ.
Output VSWR:	2 typ.
Voltage:	+5V DC
Impedance:	50Ω

Absolute Maximum Ratings*1

RF Input Power:	-20dBm
Voltage:	+7V

[1] Permanent damage may occur if any of these limits are exceeded.

Mechanical

Size*2:	44*30*15mm 1.732*1.181*0.591in
RF Connectors:	SMA female
Power Supply Connectors:	Feed Through/Terminal Post
Mounting:	4-Φ2.2mm through-hole

[2] Exclude connectors.

Environmental

Operating Temperature: -10~+50°C

Outline Drawings

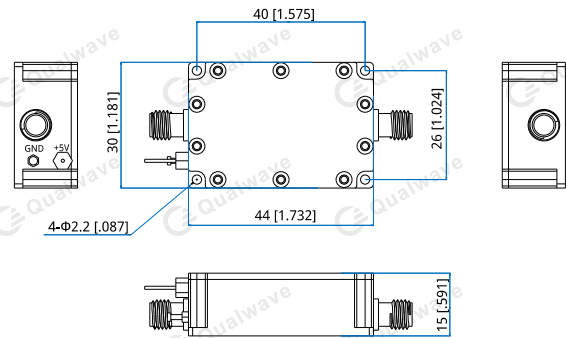

Unit: mm [in]
 Tolerance: ±0.2mm [±0.008in]

How To Order

QLA-5-1000-46-15

Customization is available upon request.

Typical Performance Curves

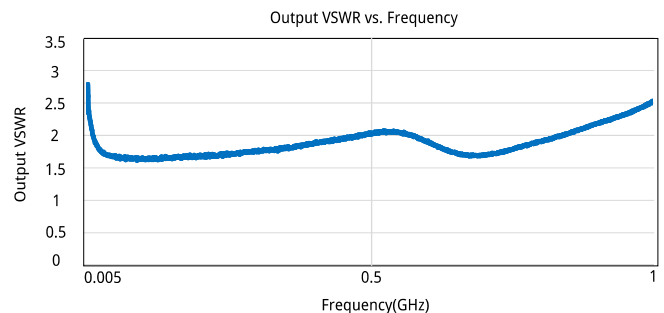
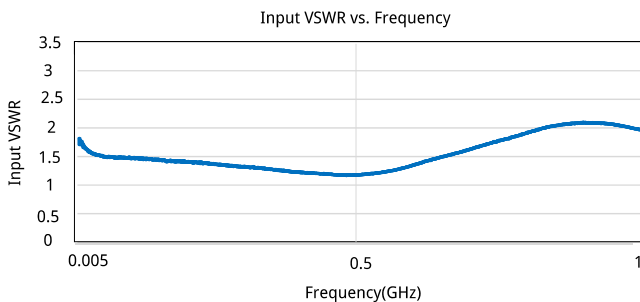

Low Noise Amplifier

