

QFA1810

DC~18GHz, 10W

Features:
 * Low VSWR
 * High Attenuation Flatness

Applications:
 * Wireless
 * Transmitter
 * Laboratory Test
 * Radar



Electrical

Frequency:	DC~18GHz
Attenuation:	1~40dB
Impedance:	50Ω
Average Power ^{*1} :	10W@25°C max.
Peak Power:	500W (5μS pulse width, 1% duty cycle) @SMA 1KW (5μS pulse width, 0.5% duty cycle) @N

[1] Derated linearly to 0.5W@120°C.

Mechanical

Size ^{*2} :	Φ30*84.5mm Φ1.181*3.327in
Size ^{*3} :	Φ15.8*47.5mm Φ0.622*1.87in
RF Connectors ^{*2} :	N Male, N Female
RF Connector ^{*3} :	SMA Male, SMA Female

[2] N connectors
 [3] SMA connectors

Environmental

Temperature: -55~+125°C

Outline Drawings

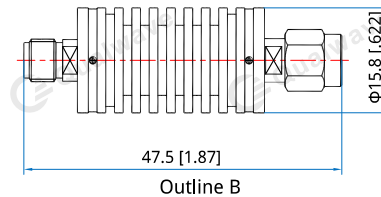
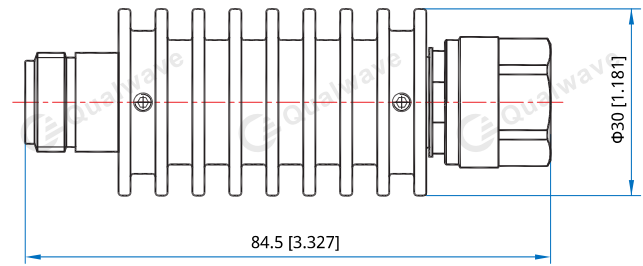

Unit: mm [in]
 Tolerance: ±2mm [±0.08in]

Attenuation Accuracy and VSWR

Frequency (GHz)	Attenuation Accuracy (±dB) vs. Attenuation (dB)				VSWR (max.)
	1~10	11~20	21~30	31~40	
DC~4	0.4	0.5	0.6	0.7	1.2
DC~8	0.5	0.6	0.8	0.8	1.25
DC~12.4	0.6	0.7	0.8	0.9	1.35
DC~18	0.8	0.9	1.0	1.2	1.45

How To Order

QFA1810-X-Y-Z

X: Frequency in GHz
 Y: Attenuation in dB
 Z: Connector type

Connector naming rules:
 N - N (Outline A)
 S - SMA (Outline B)

Examples:

To order an attenuator, DC-18GHz, N male to N female, 3dB attenuation, specify QFA1810-18-3-N.