

QAA19

1-5/8" (IF70) to 7/8" (IF45)

Features:
* Low VSWR

Applications:
* Wireless
* Transmitter
* Laboratory Test
* Radar

Electrical

Frequency:	DC~3GHz
VSWR:	1.1@DC~1000MHz max.
Dielectric Withstanding Voltage:	6000V RMS, 50Hz, at sea level, min.
Working Voltage:	2100V RMS, 50Hz, at sea level, max.
Impedance of Dielectric:	5000MΩ min.
Impedance of Contact (Center):	1.5mΩ max.
Impedance of Contact (Outer):	1.5mΩ max.
Average Power:	3.4KW@900MHz
Peak Power:	90KW max.
Impedance:	50Ω

Mechanical

RF Connectors:	1-5/8" (IF70) 7/8" (IF45)
Mating Life Cycle:	100 cycles min.
ROHS Compliant:	Full ROHS compliance
Outer Conductor:	Nickel plated brass
Dielectric:	PTFE
Inner Conductor:	Silver plated phosphor bronze
Gasket:	Silicone rubber

Environmental

Temperature: -55~+85°C

Outline Drawings

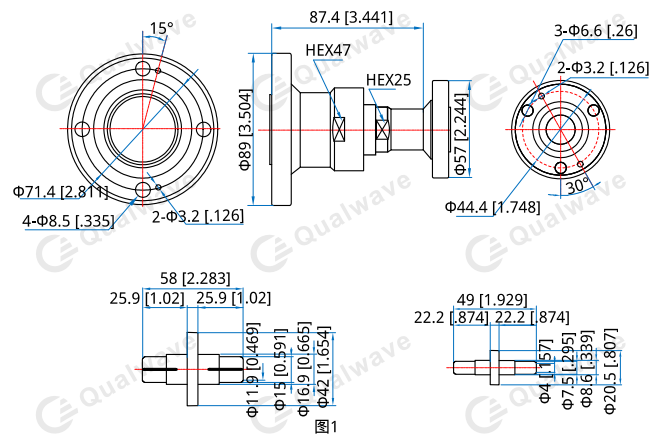

Unit: mm [in]

Tolerance: ±0.2mm [±0.008in]

How To Order

QAA19 - 1-5/8" to 7/8", Outline A

Customization is available upon request.