

QPD3-0-50000-2-2

3-Way, DC~50GHz, 2W

Features:
 * Small Size
 * Low Insertion Loss

Applications:
 * Amplifiers
 * Mixers
 * Antennas
 * Laboratory Test

Electrical

Frequency:	DC~50GHz
Insertion Loss ^{*1} :	3dB typ.
VSWR:	2 typ.
Isolation:	9dB typ.
Amplitude Balance:	±1.3dB
Phase Balance:	±8°
Impedance:	50Ω
Average Power:	2W

[1] Excluding theoretical loss 9dB.

Mechanical

Size ^{*2} :	18*18*8mm 0.709*0.709*0.315in
Connectors:	2.4mm Female
Mounting:	4-Φ2.2mm through-hole

[2] Exclude connectors.

Environmental

Operation Temperature:	-35~+75°C
------------------------	-----------

Outline Drawings

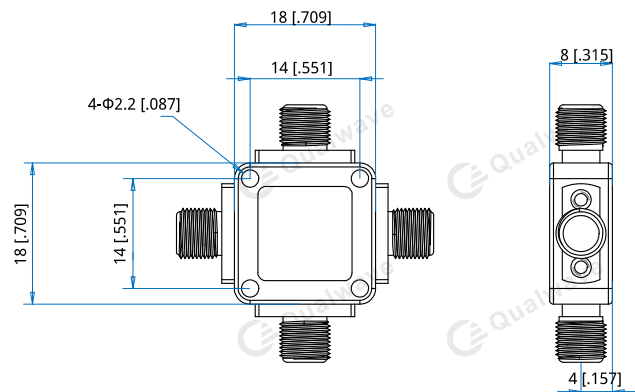

Unit: mm [in]
 Tolerance: ±0.3mm [±0.012in]

How To Order

QPD3-0-50000-2-2

Customization is available upon request.