

QPD2-4000-8000-30

2-Way, 4~8GHz

Features:
 * Small Size
 * Low Insertion Loss

Applications:
 * Amplifiers
 * Mixers
 * Antennas
 * Laboratory Test

Electrical

Frequency:	4~8GHz
Insertion Loss:	0.3dB max. (SMA) 0.5dB max. (N)
Input VSWR:	1.25 max.
Output VSWR:	1.2 max.
Isolation:	20dB min.
Amplitude Balance:	0.2dB max.
Phase Balance:	±2°
Impedance:	50Ω
Power @SUM Port:	30W max.as divider 2W max. as combiner

Mechanical

Mounting:	3-Φ2.7mm through-hole (SMA) 4-Φ2.8mm through-hole (N)
-----------	--

Environmental

Operation Temperature:	-45~+85°C
------------------------	-----------

Outline Drawings

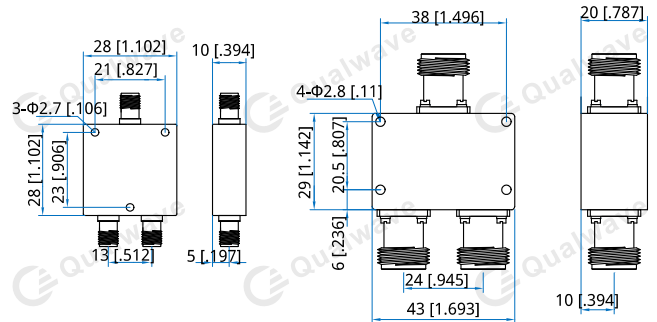

Outline A

Outline B

Unit: mm [in]
 Tolerance: ±0.5mm [±0.02in]

How To Order

QPD2-4000-8000-30-Y

Y: Connector type

Connector naming rules:
 S - SMA Female (Outline A)
 N - N Female (Outline B)

Examples:

To order a 2-way power divider, 4~8GHz, 30W, N female, specify QPD2-4000-8000-30-N.

Customization is available upon request.